

Engineering Digital Relays for Smart Electrical Grids

Introduction

When people talk about the “national” power grid, they are actually describing three power grids that are connected and operating in the 48 contiguous United States: (1) the Eastern Interconnected System (for states east of the Rocky Mountains), (2) the Western Interconnected System (from the Pacific Ocean to the Rocky Mountain states), and (3) the Texas Interconnected System.

These three systems generally operate independently of each other, although there are limited links between them and major areas in Canada are totally interconnected with our Western and Eastern power grids, while parts of Mexico have limited connection to the Texas and the Western power grids.

Electricity generated at power plants is transferred along transmission lines using high-voltage (110 kV or above) alternating current (AC). This high voltage is then sent through transformers at the other end that lower the voltage for customer use.

When large amounts of power need to be sent over long distances or transferred from one grid to another, it is more economical and more reliable to convert the AC current normally sent over the transmission lines into high-voltage direct current (HVDC). For example, the Pacific DC Intertie located in the Western United States is 846-miles of transmission lines from Oregon to Los Angeles and provides power to two to three million LA households. The connections work by converting the AC power in Oregon to HVDC, sending the HVDC power over the transmission lines to LA, and then converting the HVDC power back to AV in LA for distribution to customers.

HVDC lines are restricted only by thermal and voltage drop limits and because power is transmitted through overhead power lines there is always a danger of something coming into contact with the lines, which creates a fault or a short-circuit. Unless stopped, these faults can then cascade down the transmission lines and cause power outages so large that millions of people are affected across long distances.

Modern “smart” grid technology utilizes improved digital protective relays to gather and act on information, such as sensing when a fault has occurred on a transmission line, and automatically activating circuits that allow the grid to “self-heal,” such as by breaking the network (e.g., by opening a switch) near a fault to prevent an outage further along the lines or rerouting power, thus ensuring a more reliable supply of electricity and reducing vulnerability to natural disasters or attack.

The task of your engineering team is to develop a digital protective relay for use on HVDC transmission lines. Your team will need to consider how current, voltage, and resistance act upon each other in a network, as well as how a relay functions to receive input and then interpret the input to determine whether or not to take some pre-programmed action.

Background

On the power grids (network), digital protective relays are known as the “sentinels” or “watchdogs” of the system. They are used to detect electrical or process faults by analyzing power system voltages, currents, or other process quantities and comparing those to preset levels. If the digital relay determines that an action should be taken, for example to open or close a switch or activate an LED because of too much current or not enough voltage, it will apply its logic to complete the action without further input from a human operator.

Digital relays, also known as solid-state relays (SSRs) or microprocessor relays, work by monitoring voltage across the network between two points. An input sample of the analog voltage from a high-voltage transmission line, for example, can be proportionally reduced and then fed through a digital logic gate along with a comparable voltage. If the input voltage varies (meaning that there is a fault on the line) some action can be taken automatically by the circuit.

In order to understand how a DC relay circuit works, it is important to understand first how voltage, current, and resistance affect each other in a network and along the transmission lines of a power grid.

Ohm's law states that the current through a conductor (transmission line) between two points is directly proportional to the potential difference across the two points. Introducing the constant of proportionality, the resistance of the line, one arrives at the usual mathematical equation that describes this relationship:

Equation 1: Ohm's Law

$$I = \frac{V}{R}$$

where I is the current through the conductor in units of amperes, V is the potential difference measured *across* the conductor in units of volts, and R is the resistance of the conductor in units of ohms. More specifically, Ohm's law states that the R in this relation is constant, independent of the current.

In a circuit (network) these are visually represented as:



Figure 1: V (voltage), I (current), and R (resistance), the parameters of Ohm's law.

Source: <http://en.wikipedia.org/wiki/File:OhmsLaw.svg>

So high voltage direct current (HVDC) transmission lines would look something like this:

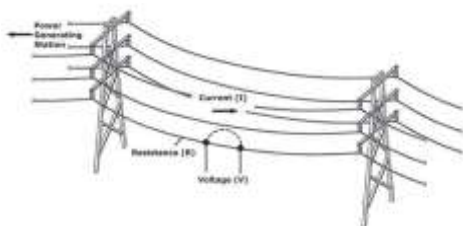

Figure 2: Sketch of High Voltage Transmission Line Network

Source: Author, VS

During the transport of energy through the lines, the rate of energy conversion is measured in watts and defined as one joule per second. The joule (J) is a unit of energy, work, or the amount of heat transferred in the International System of Units. It is equal to the energy expended (or work done) in passing an electric current of one ampere through a resistance of one ohm for one second and can be calculated using the following equation:

Equation 2: Finding Watts Using Ohm's Law

$$P = I \times \Delta V = \frac{(\Delta V)^2}{R} = I^2 \times R$$

Because the voltage across the transmission lines in HVDC is so high, it must be reduced before it is input into a digital relay circuit. In order to do this a voltage divider is required.

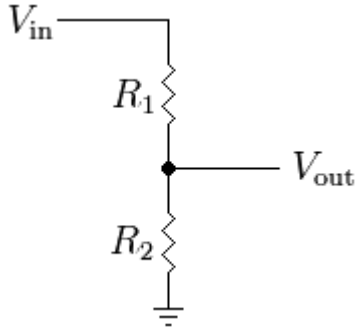

Figure 3: Simple resistive voltage divider

Source: http://en.wikipedia.org/wiki/File:Resistive_divider.png.

Equation 3: Resistive Voltage Divider

$$V_{OUT} = \frac{R_2}{R_1 + R_2} \times V_{IN}$$

$$R = \frac{R_1}{\frac{V_{IN}}{V_{OUT}} - 1}$$

Once the sampled voltage flows into the relay, it can be input into a logic gate to compare it to a given voltage. Two-input logic gates work by producing an output through some combination of inputs. For example, if Input 1 (V_{OUT}) in Figure 3 drops to 0 V when a fault occurs on the line, its input into the gate will be false (0). Under normal circumstances, the output from the gate should be 0, which means no warning lights will be activated and the circuit breaker will not be tripped. When a fault occurs, the output should change to true (1).

Figure 4: Relay Circuit Showing a Voltage Divider and Logic Gate

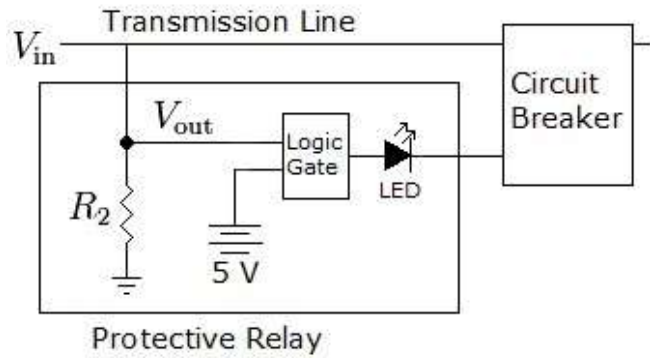

Source: Author, VS.

Table 1: Logic Gate Operation

Type	Transmission Line Input	5 V Input	Gate Output
AND	1	1	1
	0	1	0
NAND	1	1	0
	0	1	1
OR	1	1	1
	0	1	1
NOR	1	1	0
	0	1	0
EX-NOR	1	1	1
	0	1	1

Assumptions and Givens

- Length of transmission line = 1,250 km
- Line capacity = 3,100 MW
- Line Resistance = 150 Ω

Questions

11. Assuming the conditions given, what is the approximate voltage measured on the line at any point in the network?
- a. 6.82 kV
 - b. 682 V
 - c. 6820 V
 - d. 682 kV
 - e. 682 MV
12. Using the input voltage calculated in Question 1 for V_{in} and the resistance given for R_1 , determine the value of R_2 necessary to reduce the input voltage so that approximately a 5-V sample flows into the relay circuit.
- a. 0.001 Ω
 - b. 0.01 Ω
 - c. 0.1 Ω
 - d. 1 Ω
 - e. 10 Ω
13. Using the information in Table 1, which logic gate should be used when designing this circuit?
- a. AND
 - b. NAND
 - c. OR
 - d. NOR
 - e. EX-NOR

Work it Out



Additional Background

Logic gates operate on a nominal power supply voltage of 5 V. In real world applications, logic gates are designed to accept “high” and “low” signals deviating substantially from the ideal values. If a voltage signal ranging between 0.8 V and 2 V (see Figure 5) were sent into the input of a logic gate, there would be no certain response from the gate. The signal would be considered uncertain, and the logic gate manufacturer would not guarantee how the gate circuit would interpret such a signal.

Additional Assumptions and Givens

- Length of transmission line = 1,000 km
- Line capacity = 4,000 MW
- Line Resistance = 100 Ω
- Relay resistor (R_2) = 0.8 m Ω
- 1 MW can sustain 1,000 homes for 1 h

*Acceptable TTL gate
input signal levels*

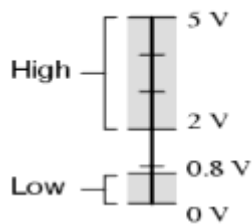

Figure 5: Acceptable Logic Gate Input Signals

Source: http://www.allaboutcircuits.com/vol_4/chpt_3/10.html

Questions

14. Assuming the conditions given, how much current would be transmitted through the lines under normal circumstances?
- 6.325 A
 - 63.25 A
 - 632.5 A
 - 6,325 A
 - 63,250 A

Work it Out



15. During a severe storm, the wind causes a tree to fall onto the transmission line and creates a fault. If the logic gate performs according to the specifications in Figure 5 (assuming a low input begins at 0.7 V), what will be the approximate capacity of the line in watts at the time the circuit breaker is tripped?
- a. 875 W
 - b. 8.75 kW
 - c. 77 MW
 - d. 770 MW
 - e. 875 MW
16. If the fault in Question 15 is allowed to continue down the transmission line to a location that contains 38,500 homes, how long will the power stay on before demand overwhelms the supply?
- a. 0 hours
 - b. 30 minutes
 - c. 1 hour
 - d. 2 hours
 - e. 20 hours or more
17. Assuming a low input begins at 0.7 V for the logic gate in the relay circuit, how can the network be changed to cause the circuit breaker to trip before the wattage falls too low?
- a. Use another type of logic gate with an output that will increase the voltage level of its input.
 - b. Replace the logic gate power supply with one that will input 0.7 V instead of the nominal 5 V.
 - c. Increase the amount of voltage flowing across the transmission lines, but keep the electric current stable.
 - d. Decrease the amount of current flowing through the transmission lines, but keep the voltage stable.
 - e. Replace the relay resistor (R_2) so V_{OUT} is reduced at a higher wattage level during the fault.

Work it Out



Additional Background

High voltage direct current is never transmitted through a single line, but three or more lines running in parallel. In a parallel circuit, the total amount of current in the circuit will be split among the branches. If the resistance of each line is the same, then the voltage of each branch will equal the voltage of the source.

Additional Assumptions and Givens

- $V_{IN} = 500 \text{ kV}$
- Total capacity of all three lines working together = 2000 MW
- Maximum current capacity for each line = 5000 A

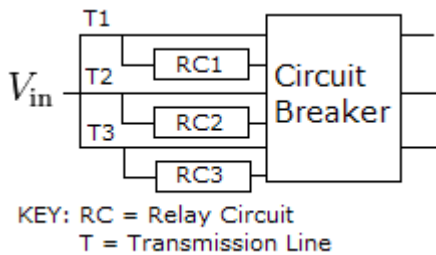

Figure 6: Three-line Parallel Transmission Circuit

Source: Author, VS

Questions

18. Assuming the normal conditions given and that the resistance of all three lines is the same, what is the current present in the T3 line?
- 445 A
 - 1335 A
 - 400 A
 - 1333 A
 - 4000 A

Work it Out



19. During a severe storm, the T1 and T2 transmission lines break. Can the remaining T3 line handle the current calculated in Question 18 flowing through the network and why?
- a. Yes, because the current in T3 will remain the same as it is under normal circumstances.
 - b. Yes, because the current will be divided by three and this is much lower than its maximum capacity.
 - c. Yes, because the current in T3 will be multiplied by three, but this is still much lower than its maximum capacity.
 - d. No, because the current will be divided by three and this is higher than its maximum capacity.
 - e. No, because the current in T3 will be multiplied by three and this is higher than its maximum capacity.

Work it Out



Additional Background

Overvoltages originated by lightning are a major cause of flashovers on overhead power lines. These flashovers may cause permanent or short interruptions, as well as voltage dips, on distribution networks. Additionally, lightning-originated surges can also damage the electronic devices connected to the network. Transmission lines are protected by “ground wires” that redirect the excess energy into the ground to prevent surges on the line. Electronics surge protectors work in the same manner, sending excess voltage into a ground wire to prevent damage to electronic components. Ground wires are chosen for their ability to conduct an electrical current (conductivity).

Additional Assumptions and Givens

resistivity-density product = resistivity ($n\Omega\cdot m$) \times density (g/cm^3)

Equation 4: Conductivity of a Material

Conductivity of a Material

$$\sigma = \frac{1}{\rho}$$

Where σ (sigma) is the conductivity of a material in siemens per meter (S/m) and ρ (rho) is the electrical resistivity of the material in ohm \cdot meters ($\Omega \cdot m$).

Table 2: Density of Conductive Materials

Material	Density (g/cm^3)	Resistivity-density product	Melting point ($^{\circ}C$)
Magnesium	1.74	76.3	650
Aluminum	2.70	72.0	660.3
Copper	8.96	150.0	1085
Silver	10.49	166.0	961.8
Gold	19.30	427.0	1064

Questions

20. Based on the information provided, why would a silver ground wire be chosen over a copper one?
- a. Silver conducts an electric charge better than copper.
 - b. Silver has a higher density than copper.
 - c. Silver has a higher resistivity-density product than copper.
 - d. Silver has a lower melting point than copper.
 - e. Silver is more resistive than copper.

Work it Out

