

Robotics- 2025

Overview

The mission of your team is to design, build, assemble, and a robot that can complete landing, dropping, identifying and picking up tasks of varying difficulty in a course designed to test the handling, maneuverability, hardware capabilities, and piloting of your robot. The event will consist of a pre-inspection and check-in of the team members, Robot and all equipment associated with the control of the robot.

ROBOTICS COMPETITORS ARE TO ENGINEER AND BUILD AN OPEN-SOURCE/COMMERCIALY AVAILABLE ROBOT. Different robots may have different capabilities, but to complete all tasks required of the event, the Robot should be able to pick up a variety of payloads and deliver them to designated areas. In addition to picking up payload's robots will have to move/avoid a variety of obstacles. Competitors are encouraged to research, design, produce, and test their robots to meet the year's challenges.

The Flight Mission:

- Mission Time: Ten (10) minute running clock.
- There will be 10 possible payloads for the robot to recover and deliver to a target area
- The course will be approximately 10'x10' course made of 1" PVC pipes and fittings
- Robots may take only one payload at a time.
- Sets of payloads will each have their own set of obstacles– Overhead obstacles, uneven terrain, and floating square. Competitors must complete each of the obstacles in the path to receiving credit for completion and drop or target identification. Described in more details below.
- Pilots will control robots via FPV or visual control methods. Secondary Pilot may use FPV (goggles, video screen, phone, etc.) to identify targets and complete payload load and drop operations.
- Payloads: All robots will start from the launch station (16"x16"x16" Garage), then choose payload to acquire, collect payload and return to the drop area Payloads must be placed in appropriate drop areas to receive credit. Payloads will be organized by the event coordinator or judge no outside devices can be used to hold/stand/modify given payloads.
- Spotters should communicate the Robot location and any targets they may see
- The Judging Team will tally up the successful drops to specified targets during the 10-minute running clock window.

Overview/Procedures

- When Robot is out of the competition tent area all batteries have to be removed and disconnected . NO EXCEPTIONS. Violation of this will result in an automatic disqualification.
- Pit Area Assignment. The Event Coordinator will provide a designated area for Robotics Teams to work on and prepare their robot for competition
- Once a payload is dropped in the competition area, the payload must be picked up and placed in the assigned drop area before pursuing another.
- Points will be scored based on the accuracy of the drop to the target and the successful completion of the obstacles for each payload group
- Time is taken, in the case of a tie in points the faster time will advance.

Regulations

1. Following all safety guidelines and precautions of this competition is the most important regulation; Violation of the safety guidelines can result in a warning or removal from the competition depending on the severity.
2. **All Robotics Competitors are Required to wear at minimum Safety glasses.**
3. When a team enters the competition tent field, only at the discretion of the Event Coordinator may the team members attach the battery cable and turn on their Robot and become ready to compete.
4. When a robot is outside of the competition tent area, all batteries must be unplugged from the robot stack, which should consist of the controller receiver and the Electronic Speed Controller (ESE). **NO EXCEPTIONS.**
5. When the competition and practice sessions are taking place and a robot is in the competition field, all robots in the pit area or outside the pit area must be **POWERED OFF**.
6. All robots must **ONLY** run within the Competition field.
7. Violations of any of the above regulations will result in disqualification.
8. If the robot goes off outside of the course a deduction of 10pts will be assessed and the robot will be placed on the starting point before starting again.
9. If a robot becomes stuck and needs human intervention a deduction of 5pts will be assessed and the robot will be placed on the starting point before starting again.

Course Obstacles/Payloads/Targets:

Payloads will be similar to the ones found- 2 of each for a total of 10 payloads

Wooden Eggs- [Here](#)

Rings, Bean Bags, and Cones - [Here](#)

Spring Toy - [Here](#)

Targets - Ten (10) pts for each successful drop completely in the target zone.

Bean bags – Bags will be placed in a 6-quart storage bin shoe box.

Wooden eggs- Wooden Eggs will be placed in a cardboard dozen egg carton the egg has to be properly placed in a position for singular egg.

Rings – Rings will be placed PVC stand shown below

Cones- Cones will have to be stacked on a single cone in the target area

Spring Toy- Spring toy must be place inside 1 of 2 [3in PVC Couplings](#)

Course Obstacles location and payloads with the obstacles will be determined at the conference and a layout will be given at the time of check in/signup for team planning.

Obstacle 1 – The Shelf -made of 1/2" PVC Pipe and a piece of 1/4" Plywood

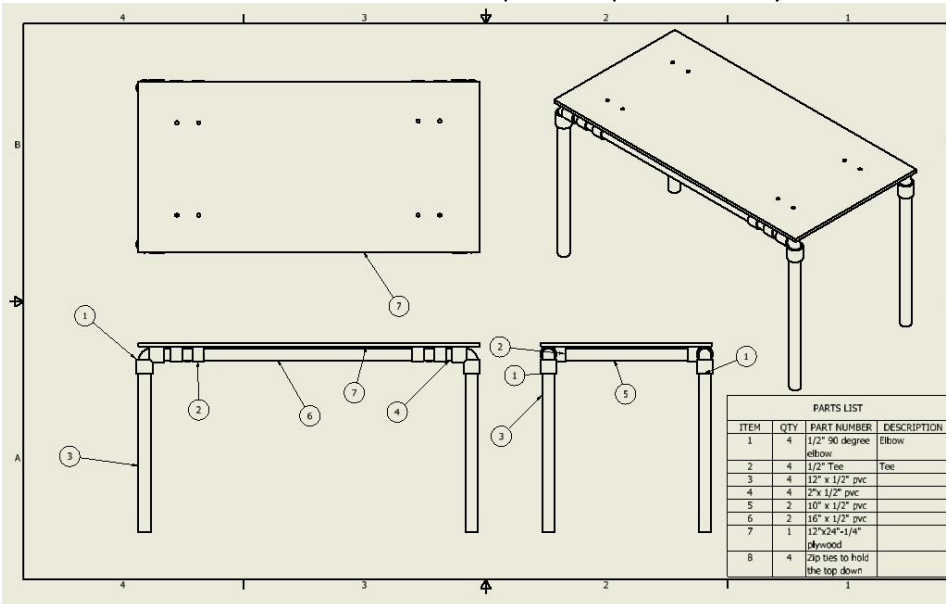

Obstacle 2– The forest – 10 pieces of 1/2x 8.5" long pvc pipes standing on end in a wooden holder for with (5pt deduction for each tree knocked over)

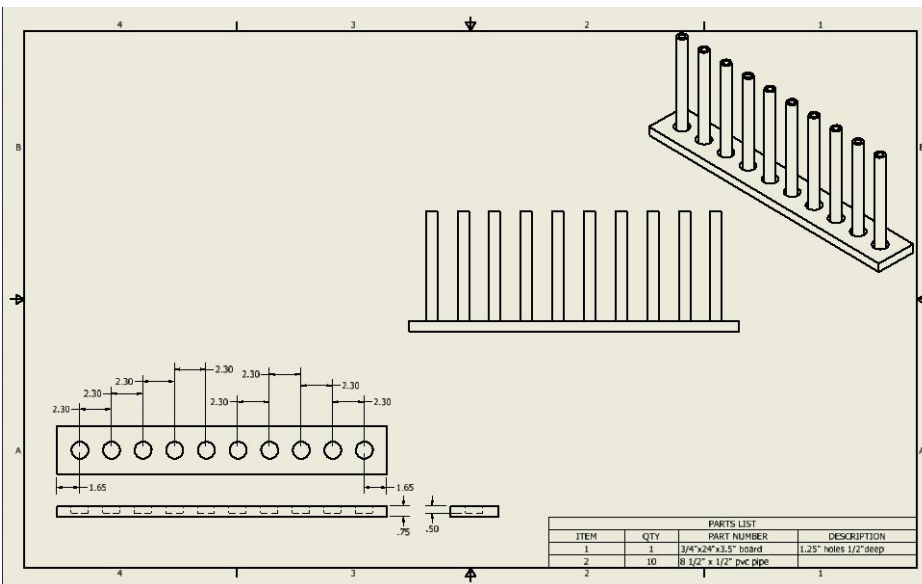

Obstacle 3 – Hills and Valleys- Made of wood mounted to a piece of ¼” plywood

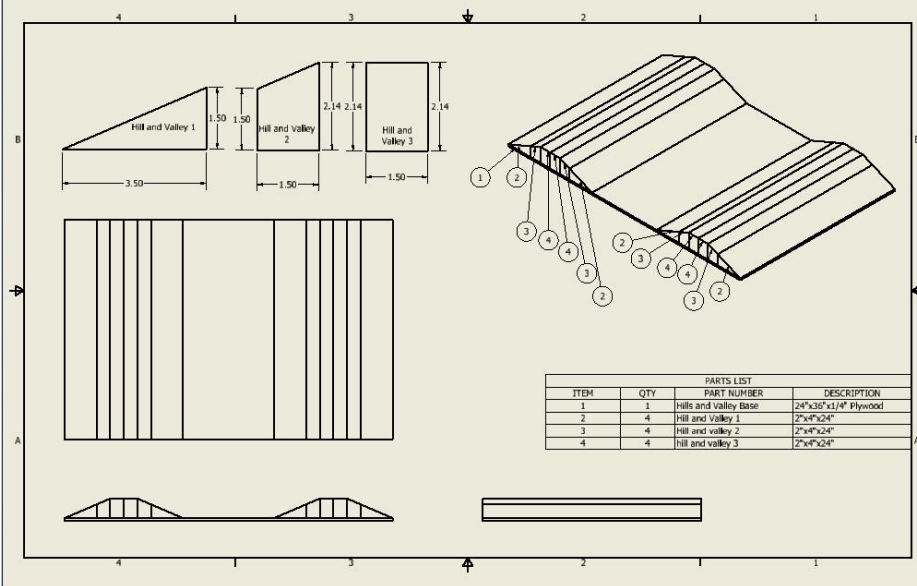

Obstacle 4- The Meadow- 24"x36" Turf Grass 1"-1.5" tall – similar to [here](#)

Obstacle 5- The track- Made of ½” and 1” Pvc pipe fittings the bars that cross the path will need to be raised by the robot before making its way to the payload

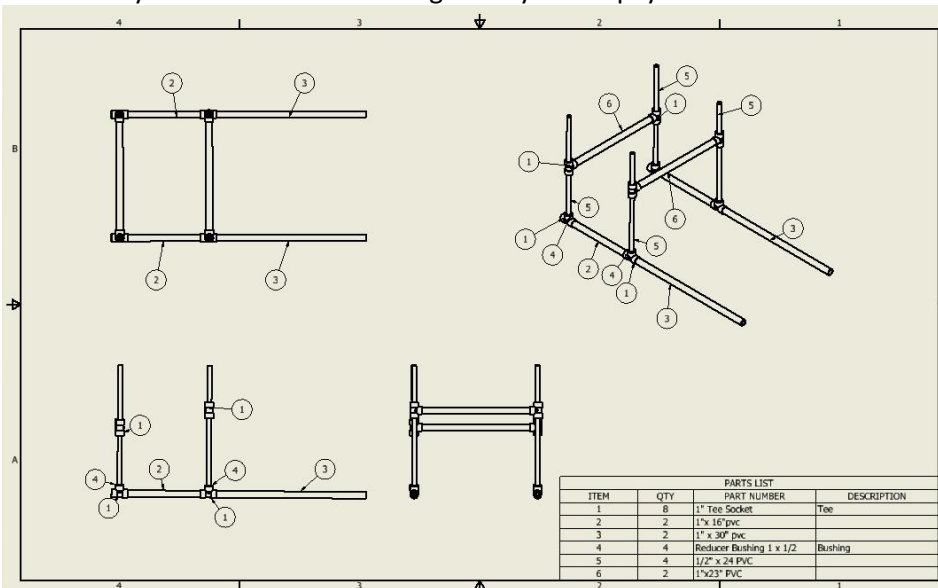

Ring Post

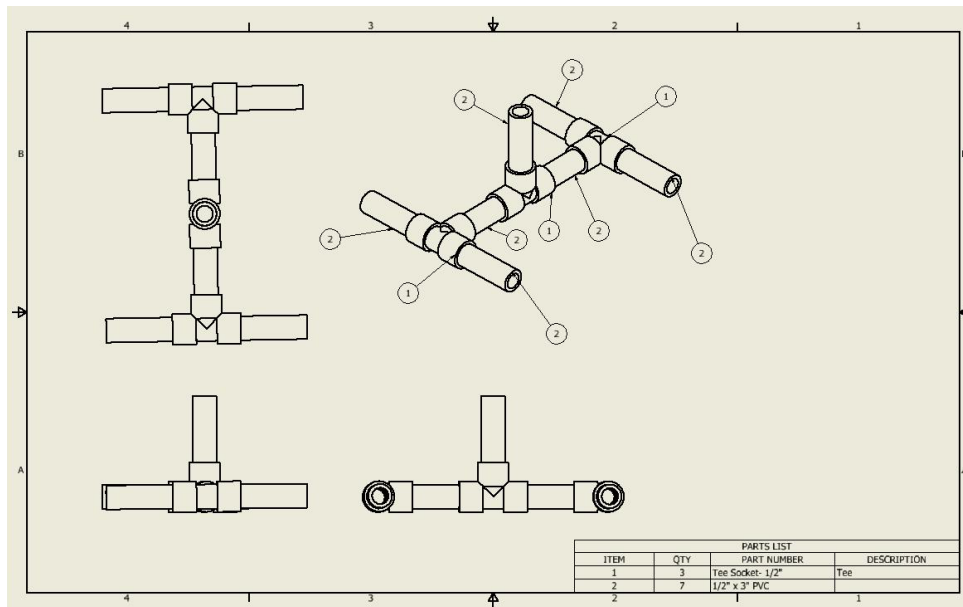

Team Number			Time	
Payload Run		Successful		Run Total Points
1	Wooden Eggs	1 2	X 10pts	
2	Cones	1 2	X 10pts	
3	Rings	1 2	X 10pts	
4	Spring Toy	1 2	X 10pts	
5	Bean Bags	1 2	X 10pts	
Deductions			Total Points	/100
Trees knocked over	#		X 2.5 pts	
Times Robot goes out of course boundaries	#		X 10 pts	
Times Human Interactions needed with physical robot while it is on course	#		X 5 pts	
			Total Deduction	-
			Final Total Points	/100

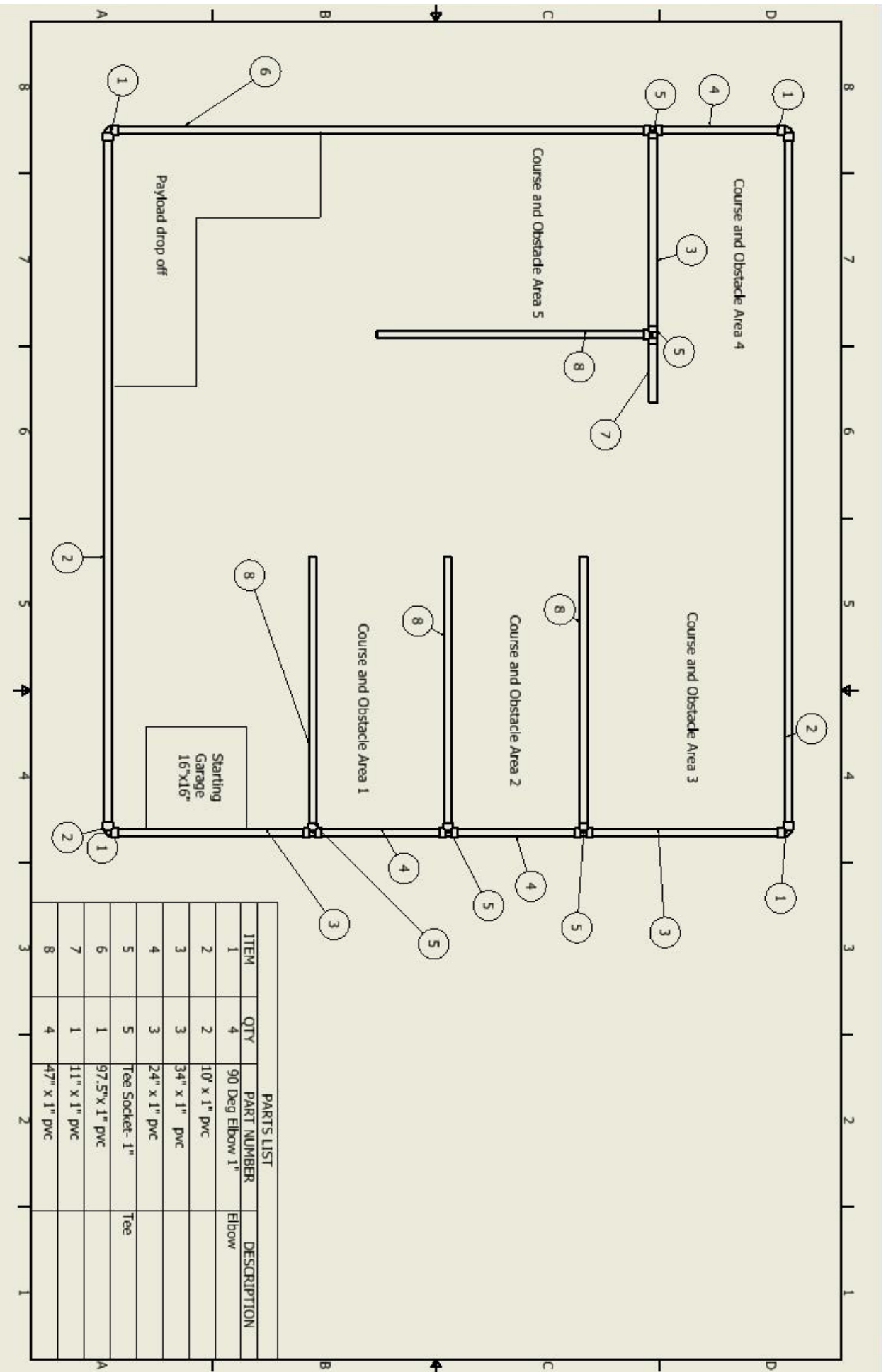

PARTS LIST

ITEM	QTY	PART NUMBER	DESCRIPTION
1	4	90 Deg Elbow 1"	Elbow
2	2	10" x 1" pvc	
3	3	3/4" x 1" pvc	
4	3	2/4" x 1" pvc	
5	5	Tee Socket - 1"	Tee
6	1	97.5" x 1" pvc	
7	1	11" x 1" pvc	
8	4	47" x 1" pvc	